



Lightning and Surge Protection for Electric Bus Charging Stations

White Paper



Contents

- Threat scenarios
- Normative requirements
- Lightning protection zone concept
- Protection solutions
- External lightning protection
- Surge protection
- Earthing
- Equipotential bonding
- Protection against arc faults



Lightning and Surge Protection for Electric Bus Charging Stations

White Paper



Background

The energy and mobility revolution is in full swing and progressing continuously. The constant further development of technologies – such as battery technology, for example – is allowing for the breakthrough of electric mobility; not only in the field of electric vehicles, but also in local public transport. More and more operators of bus fleets, such as municipal utility companies, are replacing their previous diesel buses with electric buses and developing new mobility concepts. To charge electric buses, there are essentially two different charging concepts, which are being pushed as a choice between one or the other, or both together to complement each other. On the one hand, there is depot charging. This involves the bus batteries being supplied with power overnight at the depots to ensure seamless driving operation the following day.

On the other hand, there is opportunity charging. If the capacity of the batteries does not suffice, the electric buses are supplied with power at bus stops and bus terminals through a pantograph charging station. This can either be a short charging cycle at a bus stop while the passengers get on and off, or at the bus terminals where the buses stop for much longer.

The basic system architecture for depot charging and opportunity charging is generally the same. This consists of a transformer station, which is supplied by the medium-voltage grid. Subsequently, the AC voltage is converted into DC voltage by a converter. The converted DC voltage is also stored in batteries to ensure stable load management. After this, the buses are supplied with power through a conductive charging system or pantograph charging system. The individual system components include not only power supply lines, but also copper-based information and communication technologies, through which the system components are interlinked with each other, but also linked to the traffic control centre, for example.

In order for the bus schedules to be adhered to, and therefore customer satisfaction to be ensured, permanent availability of the electric buses and the charging infrastructure is essential. For this reason, dangers posed by lightning currents and surges must not be ignored. By protecting the overall system

architecture, efficient operation and system / operational safety are ensured, while normative requirements are fulfilled at the same time.

Dangers posed by thunderstorms

Several billion flashes of lightning occur around the world every year. In Germany alone, 1.5 million lightning events are counted on average every year, with the trend increasing. If lightning strikes in close proximity, damage to buildings and infrastructure can result, as well as to the electric mobility charging infrastructure. Lightning strikes can lead to fires and/or to surge damage to electrical devices and systems. For example, if lightning strikes a lighting mast, a dangerous potential gradient area arises, which can wreak damage within up to 2 km.

The switching of electrical energy at a charging post, for example, or during switching operations in transformer stations produces switching overvoltages and can also have negative consequences as a result. Even just a low amount of energy is often enough to cause damage.

What happens if lightning strikes during the charging process?

The permanent availability of electrical energy is a crucial factor for charging processes, especially in local public transport. Due to its largely outdoor installation, the entire charging infrastructure and its delicate electronic components are greatly susceptible to the effects of lightning discharges. It is not only inductive and capacitive injections from remote strikes that cause serious damage. In the case of direct strikes, or those close by, dangerous partial lightning currents can also be injected into the charging infrastructure. If an electric bus is being charged during a direct, close by or remote lightning strike, the induced voltages and currents can destroy not only the entire charging infrastructure, but also the bus's batteries and the delicate on-board electronics. This will result in serious financial repercussions and high labour costs for maintenance and repair work. In order to prevent this, an effective, reliable and comprehensive lightning and surge protection concept must be considered.

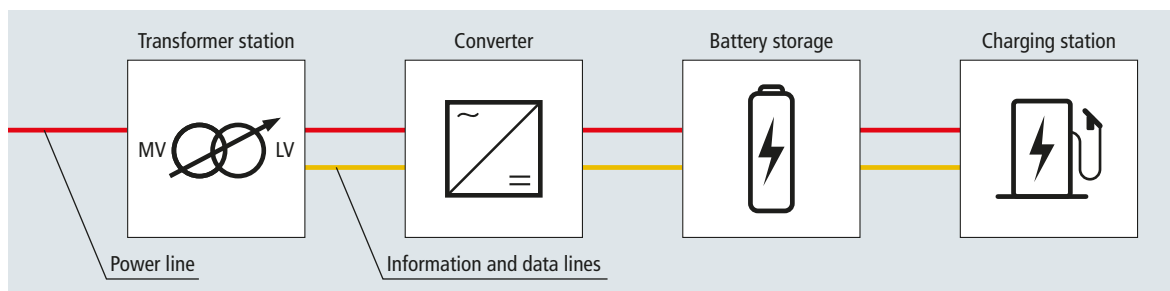

Figure 1 Typical system architecture of the charging infrastructure for electric buses

Lightning and Surge Protection for Electric Bus Charging Stations

White Paper

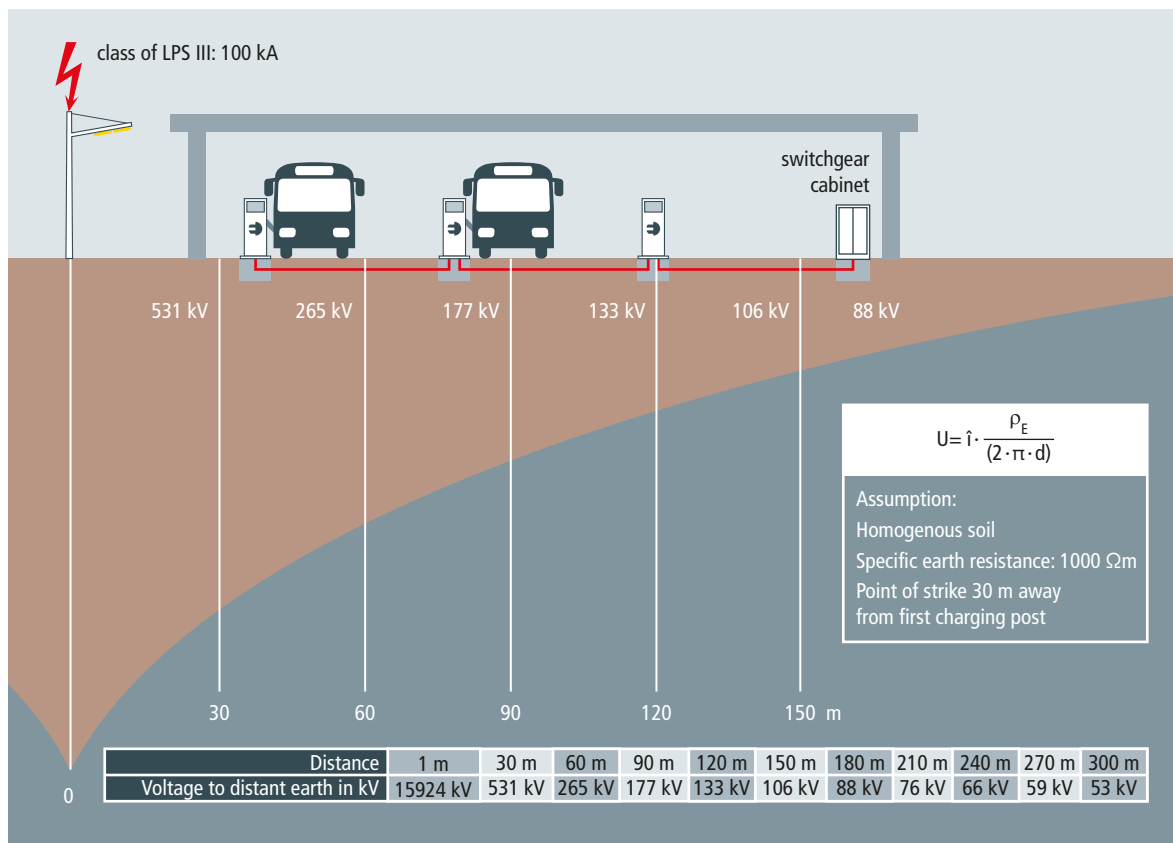

Figure 2 Potential gradient area propagation (example illustration)

Normative requirements

Risk analysis

A risk analysis is part of risk management. The purpose of a risk analysis is to determine the risk of damage from direct and indirect lightning strikes for a structure, including people and equipment. Included in the risk analysis are the local conditions and the type of use of the structure, amongst other things. If the class of the lightning protection system (LPS) is not specified by building regulations, this is determined after assessing the risk of damage as per IEC 62305-2 (EN 62305-2). The DEHNsupport Toolbox software can be used here for a practical and easy implementation of the risk analysis. If an external lightning protection system is required in line with IEC 62305-2 (EN 62305-2), it must be set up according to IEC 62305-3 (EN 62305-3) based on the related class of LPS.

Since people are regularly at bus stops and in depots, a specific evaluation concerning step voltage and touch voltage is also necessary.

A comprehensive lightning protection concept generally consists of:

- ➔ An external lightning protection system, including air-termination systems
- ➔ Fully intermeshed earthing and equipotential bonding
- ➔ Internal lightning equipotential bonding
- ➔ Surge protection

The external lightning protection system consists of air-termination systems and down conductors. Lightning is intercepted by air-termination rods at previously defined strike points, to then subsequently be dissipated via the down-conductor system, maintaining separation distances, and distributed widely across the earthing system.

The internal lightning equipotential bonding and surge protection protect all the parts of the system – from the transformer station to the charging station and the electric bus – from lightning currents and surges. Based on the lightning protection zone concept, the correct lightning current and surge arresters are selected, both for power and data lines. With such a comprehensive protection concept, people and the charging infrastructure are reliably protected in equal measure.

Lightning and Surge Protection for Electric Bus Charging Stations

White Paper



Additional normative requirements

The IEC 60364 group of standards constitutes installation standards and must therefore always be applied to the fixed installation, also for bus charging stations, and for installations with and without an external lightning protection system.

IEC 60364-4-44 deals with the protection of electrical installations with transient surges resulting from atmospheric influ-

ences that can be transmitted over the power grid, including direct lightning strikes into the supply lines and transient surges resulting from switching operations. It provides a statement on whether surge protection measures are required, weighs up the location risk, defines overvoltage categories and the related, required measurement impulse withstand voltages of the equipment and defines whether additional surge protection equipment is necessary.

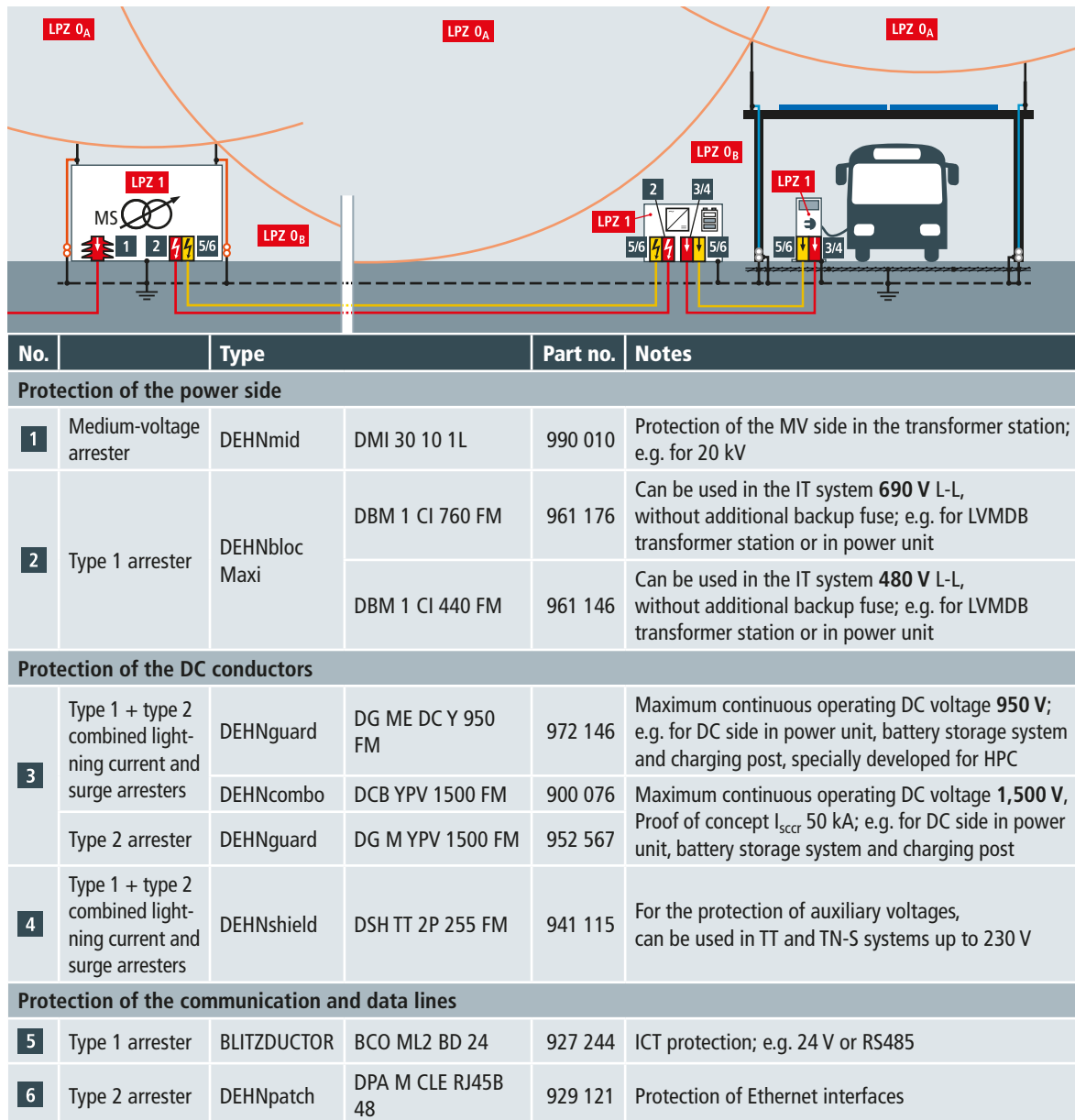

Figure 3 Example charging infrastructure, consisting of separate transformer station and separate power and charging units

Lightning and Surge Protection for Electric Bus Charging Stations

White Paper



Furthermore, the necessary availability of the system is dealt with.

If lightning and surge protection measures as outlined in IEC 60364-4-44 and IEC 62305 are used, then they must be installed as per IEC 60364-5-53. IEC 60364-5-53 describes the selection of lightning and surge arresters and how they are to be installed.

Lightning protection zone concept

The potential strike points are deduced based on the determined class of lightning protection system (e.g. LPS III) with the aid of the rolling sphere model. In this process, a defined rolling sphere is rolled over the entire installation. The radius of the sphere varies depending on the class of LPS. Based on this, the air-termination systems of the external lightning protection system are positioned so that the entire installation is in the protected volume. This results in the classification of the so-called lightning protection zones (LPZs). The external zone (LPZ 0) is split into two zones. LPZ 0_A is exposed to direct lightning strikes and the full magnetic field of the lightning. Zone LPZ 0_B is protected against direct lightning strikes but susceptible to the electromagnetic field of the lightning.

The inner zones (LPZ 1–n) are protected against direct strikes but susceptible to partial lightning currents. The right lightning and surge protective device must be chosen depending on the zone boundary. At the boundary from LPZ 0_A to LPZ 1 or higher, protective devices that are capable of discharging considerable partial lightning currents without destruction must be used. These protective devices are referred to as type 1 SPD lightning current arresters. According to the lightning protection zone concept, all incoming power and communication lines from LPZ 0_A must be incorporated into the lightning equipotential bonding with type 1 SPDs. At the boundary from LPZ 0_B to LPZ 1 and higher only low-energy impulse currents caused by voltages induced on the system or surges generated in the system must be coped with. These protective devices are referred to as type 2 SPD surge arresters.

The implementation of the lightning protection zone concept is an important prerequisite for subsequent safe and undisturbed operation.

External lightning protection measures

In most cases, the buses in the depots are charged with conductive charging stations. These are either under a roof or outdoors.

In addition to air-termination systems, an external lightning protection system also includes down-conductor systems. To protect the installation from direct lightning strikes, air-termination rods are arranged on the roof of the depot charging stations so that the entire structure is in the protected volume of the air-termination systems. When setting up/routing the

air-termination rods and down conductors, it is important to maintain separation distances. If the separation distance cannot be maintained, uncontrolled flashover and sparking will arise between parts of the external lightning protection system and electrically conductive parts of the structure, such as metal pipes or, for example, photovoltaics, air-conditioners and LED lights. This leads to electrically and mechanically damaged parts of an installation, and even to fires! Since it is often difficult to maintain the separation distance in practice, an insulated lightning protection system is recommended. To this end, high-voltage-resistant, insulated conductors, also referred to as HVI conductors, are used. These consist of a high-voltage-resistant insulation to prevent flashovers and dangerous sparking. If the separation distance can be maintained, conventional air-termination rods and down conductors can be used. Depending on the system architecture, the transformer station may be in the protected volume of the arranged air-termination rods. Should this not be the case, then it must also be equipped with an external lightning protection system.

With opportunity charging, the buses are charged during driving operations at bus stations, mostly using pantographs. In the event of a direct lightning strike, metallic parts of the installation may melt. This can lead to subsequent damage, for example, if rainwater then penetrates the system and damages it. As described above, electrical damage must also be taken into consideration. To prevent such damage, fitting the charging stations with an insulated external lightning protection system is also advisable. Using HVI conductors is also recommended for this.

If people are near to fast charging stations or in the depots during a thunderstorm, the step voltage and touch voltage must be kept to an acceptable level. To prevent people from getting injured from touch voltages, a CUI conductor should be used as a down conductor instead of a conventional down conductor.

If there are defined areas in which people can permanently be situated (e.g. bus shelters, bus stops, charging posts, etc.), then the emergence of step voltages must be prevented by means of potential control. In practice, stainless steel (V4A) mesh mats capable of carrying lightning currents are installed in the area where people are located.

In order to achieve a safe earthing arrangement and to limit potential rise to a minimum, setting up an intermeshed earthing system inside the depots or fast charging stations is unavoidable. In an intermeshed earthing system, all the parts of the installation (transformer station, inverter, battery storage system, charging post, operations building, etc.) are finely meshed together. This can be achieved with stainless steel (V4A) round wire, for example. In order to ensure the permanent functionality and resistance of the clamping points, using anti-corrosion tape is necessary.

Lightning and Surge Protection for Electric Bus Charging Stations

White Paper

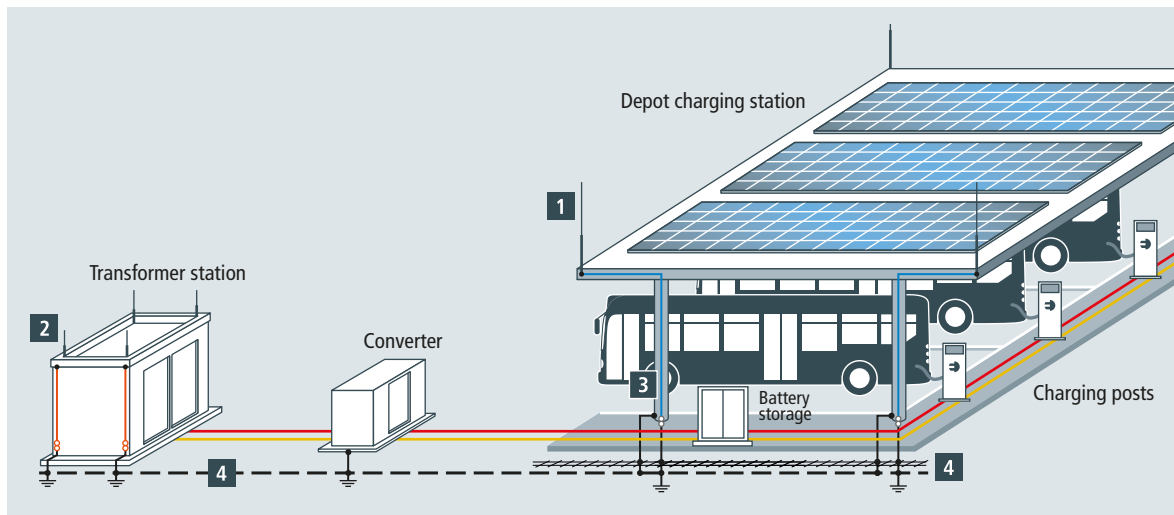

Figure 4 Example layout of charging infrastructure in a bus depot

No.	Type	Part no.	Notes	
External lightning protection system / down conductors				
1	HVI Conductor in supporting tube with air-termination rod	HVI 20 M L6M SR3200 IP RFS2500 GRP AL	819 328	High-voltage-resistant, insulated down conductor for maintaining separation distances
2	Air-termination rod (AL)	FS D40 16 10 4000 KSV AL	105 170	Air-termination rod for fixing to walls or structures
3	CUI conductor (CU/vPE)	CUI L 20 GR 3.5M	830 208	Protection against touch voltage
Earthing and equipotential bonding				
4	Equipotential bonding bar (Cu/gal Sn)	PAS 11AK	563 200	Equipotential bonding bars for protective and functional equipotential bonding
	Round wire (StSt, V4A)	RD 10 V4A R80M	860 010	Round wire 10 mm as radial earth electrode
	Strip steel (StSt, V4A)	BA 30X3.5 V4A R25M	860 325	Stainless steel strip for the ring equipotential bonding
	Earth rod (StSt, V4A)	TE 20 1500 AZ V4A	620 902	Earth rod for setting up earthing systems
	Connection clamp (StSt, V4A)	AK 8.10 AQ4 50 TE20 25 V4A	540 121	Connection clamps for the cross/parallel connection of round conductors to earth rods
	Mesh mat (StSt, V4A)	GMA 250 2000X1000X4 V4A	618 214	Mesh mat for potential control
	Connecting clamp (StSt, V4A)	MMVK 3.5 8.10 SKM8X30 V4A	540 271	Connecting clamp for connecting mesh mats to earth-termination systems
	Anti-corrosion tape (petrolatum)	KSB 50 L10M	556 125	For the enclosure of above/underground connections
	DEHNIT (special clay)	DEHNIT 25KG	573 000	Earth improvement material

Table 1 Example selection guide for components of the external lightning protection system, earthing and potential control (figure 4 and 5)

Lightning and Surge Protection for Electric Bus Charging Stations

White Paper

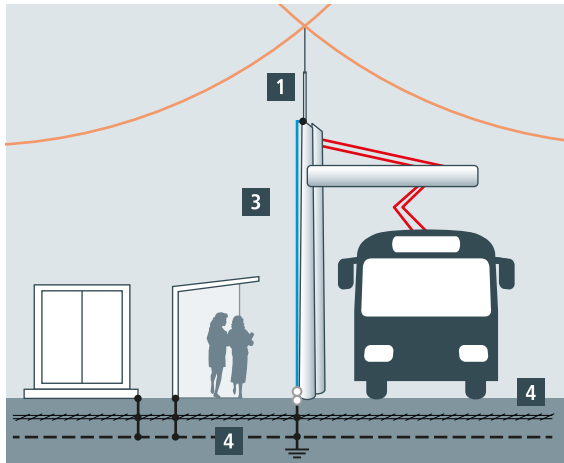

Figure 5 Example arrangement for opportunity charging using a pantograph, protected by HVI, including potential control for preventing step voltage hazards

Lightning protection standard IEC 62305 recommends an earth resistance of $<10 \text{ Ohm}$. If the earth resistance is still too high despite the intermeshing, the earth resistance can be further reduced using earth rods.

There is also the option of using what is essentially an earth improvement material. DEHNIT is the suitable choice here: an extremely swellable, moisture-retaining special clay for producing a conductive earth electrode enclosure.

Internal lightning protection measures

In order to guarantee the power supply, each part of the entire charging infrastructure must be in working order. If only one part is damaged, this has an impact on the entire system, so that charging cannot be performed. Since the system components are not always in close proximity, an effective protective distance of the SPDs must be ensured. As a rule, which lightning protection zones the respective parts are positioned in, and from which lightning protection zones the respective incoming and outgoing conductors are running, must be evaluated in detail. Based on this, the correct lightning current and surge arresters must be selected in accordance with the description in the lightning protection zone concept section. The transformer station is the centrepiece of the charging infrastructure and contains delicate electronic components, such as:

- ➔ Monitoring and telecontrol/telecommunications
- ➔ Regulated distribution transformers and longitudinal voltage regulators
- ➔ Communication and control equipment

- ➔ Remote-controlled switch-disconnectors/circuit breakers at the medium-voltage level, etc.

Firstly, the protection of the medium-voltage side of the transformer should be considered. This is performed using medium-voltage arresters of the DEHNmid product range. It is not only the medium-voltage side on the transformer that needs protecting, though – there is also the low-voltage side where the sensitive secondary system is installed. Since there is coupling of disturbance variables on the MV side, surges are demonstrably transmitted to the low-voltage side which exceed the insulation strength of the installed equipment, thus damaging it. By using a DEHNguard ACI (type 2) surge arrester, this can be prevented.

The ACI technology offers many advantages over conventional SPDs. Since an external backup fuse is not required, not only are significant space-savings provided, design errors relating to the selection and dimensioning of the backup fuse are also avoided. Furthermore, a cross-sectional area of just 6 mm^2 is sufficient.

If direct lightning strikes or ones close-by are anticipated based on the risk assessment, in addition to inductive and capacitive coupling, the coupling of galvanic partial lightning currents on the low-voltage cabling will also occur.

In this case, instead of a type 2 arrester, a type 1 arrester is to be used in the LVMDB, such as the DEHNvenCI or DEHNbloc Maxi CI. The arresters with CI technology (Circuit Interruption Fuse Integrated) contain an integrated backup fuse. This eliminates the effort of dimensioning and choosing a matching fuse and saves a maximum amount of space.

Depending on the structure of the overall system, the transformer, the converter and the battery storage system can be located in a compact station, from which the corresponding charging post is supplied with a DC voltage. To choose the right arresters for the DC side, an equal amount of attention must be paid to which lightning protection zone the supply cables and information cables of the charging station are coming from. If the charging station or the cabling is located in lightning protection zone 0_A , then combined arresters such as DEHNguard ME DC or DEHNcombo 1500 must be chosen. If the charging station or cabling is in zone 0_B or higher, protection is ensured with a type 2 arrester. Depending on the system voltages, arresters from the DEHNguard SE DC or DEHNguard M YPV product range are the right arresters for protecting the DC side of the compact station. Depending on the system architecture – for example, if the conductor and converter units are positioned separately from the compact station – protection of the input and output side must be considered in equal measure.

The last system component left to protect is the now the charging station, so as to be able to ensure the protection of the electric bus itself. Suitable for protecting this is, for example,

Lightning and Surge Protection for Electric Bus Charging Stations

White Paper

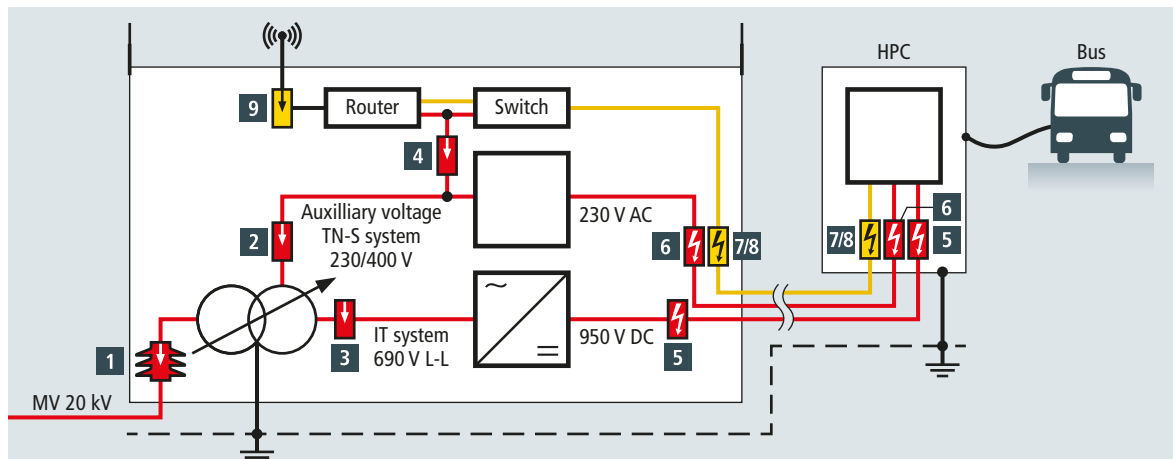

No.	Type	Part no.	Notes
Protection of the power side			
1	Medium-voltage arrester	DEHNmid DMI 30 10 1L	990 010 Protection of the MV side in the transformer station; e.g. for 20 kV
2	Type 2 arrester	DEHNguard DG M TT ACI 275 FM	952 341 Protection of the LVMDB in the transformer station, use without additional backup fuse with ACI technology, 230/400 V
3	Type 2 arrester	DEHNguard DG M WE 600 FM	952 307 Can be used in the IT system 690 V L-L, e.g. for LVMDB transformer station or in power unit
		DEHNguard DG SE CI 440 FM	952 920 Can be used in the IT system 480 V L-L, without additional backup fuse; e.g. for LVMDB transformer station or in power unit
4	Arrester type 2 + type 3	DEHNcord DCOR 3P TT 275 FM	900 439 Can be used in TT and TN-S system 230/400 V, compact SPD for additional protection of terminal equipment; e.g. for monitoring units
Protection of the DC conductors			
5	Type 1 + Type 2 combined lightning current and surge arresters	DEHNguard DG ME DC Y 950 FM	972 146 Maximum continuous operating DC voltage 950 V, e.g. for DC side in power unit, battery storage system and charging post
		DEHNcombo DCB YPV 1500FM	900 076 Maximum continuous operating DC voltage 1,500 V, Proof of concept I_{scrr} 50 kA; e.g. for DC side in power unit, battery storage system and charging post
6	Type 1 + Type 2 combined lightning current and surge arresters	DEHNshield DSH TT 2P 255 FM	941 115 For the protection of auxiliary voltages, can be used in TT and TN-S systems up to 230 V
Protection of the communication and data lines			
7	Type 1 arrester	BLITZDUCTOR BCO ML2 BD 24	927 244 ICT protection; e.g. 24 V or RS485
8	Type 2 arrester	DEHNpatch DPA M CLE RJ45B 48	929 121 Protection of Ethernet interfaces
9	Type 2 arrester	DEHNgate DGA G SMA	929 039 Protection of coaxial systems, SMA connection

Figure 6 Example charging infrastructure, consisting of a compact station with integrated transformer and converter unit and separated charging units

Lightning and Surge Protection for Electric Bus Charging Stations

White Paper



the DEHNguard ME DC with DCD technology, which has been specially developed for use in high-power charging, safely interrupting it in the event of a DC electric arc. With rooftop charging cables, the charging cable is suspended from the ceiling of the depot charging station. In most cases, the conductors from the charging station to the bus are longer than 10 metres. In order to ensure full protection as per IEC 60364-5-53, the conductor must be cut/disconnected in the immediate vicinity of the electric bus and fitted with an additional protection box with suitable lightning current and surge arresters.

In turn, for the protection of copper-based data cables, the BLITZDUCTORconnect is used for 24-V signals, DEHNpatch for Ethernet or DEHNgate SMA for external, coaxial antenna systems.

As described in the previous sections, the lightning current and surge arresters are to be selected based on the prevailing system architecture, system voltages, system configurations, interfaces and the specific lightning protection zone concept. Please refer to the selection tables for **figures 3 and 5**.

Protection against arc faults in the charging infrastructure for electric buses

It is not only the threats from lightning and surges posed on the charging infrastructure that are to be considered, but also the effects of electrical arc faults. The latter can not only totally destroy the switchgear installation causing lengthy downtime, but also put people at considerable risk.

An arc fault releases enormous amounts of energy in milliseconds. Extreme heat, toxic gases and explosive pressure conditions pose a risk of fatality to anybody near the electrical installation. The employer bears responsibility for protecting their employees – this is stipulated by the German Occupational Health and Safety Act.

The latest version of the NFPA(R) 70 NEC, section 240.87, requires an arc flash mitigation solution for low-voltage switchgear installations with incoming circuit breakers which are designed or can be configured for 1,200 A or more. There is an array of solutions for meeting this requirement.

One option is an active arc fault protection system. This kind of system also corresponds with the hierarchy of control pyramid. A technical solution is preferable to personal protective equipment (PPE).

It is here that the DEHNshort arc fault protection system contributes to the seamless charging of the electric buses, in addition to the protection of people in the electrical installations. If an arc fault occurs in the low-voltage switchgear installation of the charging infrastructure, the power supply will no longer be available to an unlimited degree due to the damage incurred to the system. This results in a reduced transport capacity, and consequently to considerable delays for passengers. By using the active protective system DEHNshort, damage can be kept to a minimum and system availability can be increased.

You can find further information at:
<https://www.dehn-international.com/en/dehnshort-arc-fault-protection-system>

Service

Our comprehensive range of solutions is also supplemented by numerous services:

- ➔ DEHNconcept planning service (planning of lightning protection systems)
- ➔ DEHNsupport Toolbox design software (e.g. for risk analysis and separation distance calculation)
- ➔ DEHN test centre, DAKkS-accredited, e.g. for system checks for proof of protection
- ➔ Seminars and webinars of the DEHNacademy
- ➔ LIGHTNING PROTECTION GUIDE book, brochures and catalogues
- ➔ Periodic inspections of earthing and short-circuiting devices, voltage detectors and insulating sticks
- ➔ All-encompassing advice and support, also face-to-face on site

www.dehn-international.com/partners



Surge Protection
Lightning Protection
Safety Equipment
DEHN protects.

DEHN SE + Co KG
Hans-Dehn-Str. 1
Postfach 1640
92306 Neumarkt, Germany

Tel. +49 9181 906-0
Fax +49 9181 906-1100
info@dehn.de
www.dehn-international.com



www.dehn-international.com/partners

Type designations of products mentioned in this white paper which are at the same time registered trademarks are not especially marked. Hence the absence of TM or [®] markings does not indicate that the type designation is a free trade name. Nor can it be seen whether patents or utility models and other intellectual and industrial property rights exist. We reserve the right to introduce changes in performance, configuration and technology, dimensions, weights and materials in the course of technical progress. The figures are shown without obligation. Misprints, errors and modifications excepted. Reproduction in any form whatsoever is forbidden without our authorisation.